



5" DTH HAMMER

STENUICK05I

CATEGORY

Drilling equipment

FEATURES

Recommended for:
 - water well drilling
 - geothermal
 - civil engineering

TECHNICAL CHARACTERISTICS

Top thread: 3"1/2 REG Pin
 Outside diameter: 118 mm
 Length: 1016 mm
 Bit shank: DHD350
 (available with SD5 shank)
 Pressure range: 7 to 24 bars
 Bit range: 127 to 178 mm
 Weight: 66 kg



AIR CONSUMPTION

| Pressure | | Air consumption | |
|----------|-----|-----------------|-----|
| bar | psi | m3/min | cfm |
| 7 | 100 | 5.7 | 200 |
| 10 | 150 | 7.3 | 260 |
| 14 | 200 | 9.9 | 350 |
| 17 | 250 | 12.2 | 430 |
| 24 | 350 | 15.5 | 550 |

BIT FOR STENUICK05I / DHD350 / COP54

| Diameter | | Bit types | | | Oversize diameter | Weight (kg) |
|----------|-------|-----------|---|---|-------------------|-------------|
| mm | inch | 1 | 2 | 3 | | |
| 127 | 5" | | | ● | | 15.0 |
| 140 | 5"1/2 | | | ● | | 17.0 |
| 149 | 5"7/8 | | | ● | | 18.0 |
| 152 | 6" | | | ● | | 18.0 |
| 165 | 6"1/2 | | | ● | ● | 20.0 |
| 178 | 7" | | | ● | ● | 21.0 |

SPARE PARTS LIST

| Rep. | Reference | Designation |
|------|--------------|---------------------|
| | STENUICK05I | Marteau 5" DHD350 |
| 1 | STEN05REP01 | Top adaptor |
| 2 | STEN05REP02 | O ring |
| 3 | STEN05REP03 | NR valve |
| 4 | STEN05REP04 | NR valve spring |
| 5 | STEN05REP05 | NR valve housing |
| 6 | STEN05REP06 | Spacer |
| 7 | STEN05REP07 | Plug |
| 8 | STEN05REP08 | Air distributor |
| 9 | STEN05REP09 | O ring |
| 10 | STEN05REP10 | Liner |
| 11 | STEN05REP11I | Piston |
| 12 | STEN05REP12 | Cylinder |
| 13 | STEN05REP13 | Snap ring |
| 14 | STEN05REP14 | O ring |
| 15 | STEN05REP15I | Bit retaining rings |
| 16 | STEN05REP16I | Chuck |
| 17 | | Foot valve |
| 18 | | Bit |

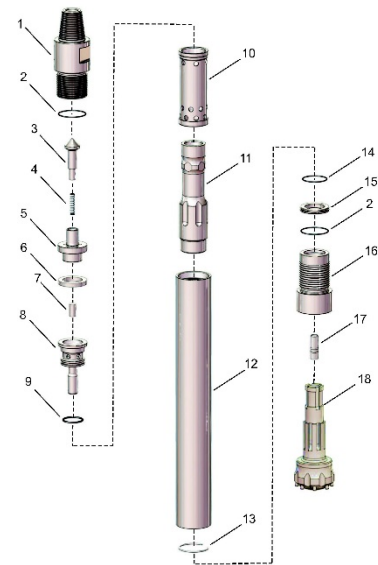

34, rue des Châtelliers
 BP 2803
 45028 Orléans Cedex 1
 Téléphone : 02 38 86 50 46
 Télécopie : 02 38 86 78 91
 Email : stenuick@stenuick.fr
 Site : www.stenuick.fr

IMPORTANT:

The technical characteristics can be modified without advance notice



5" DTH HAMMER

STENUICK05M

FEATURES

Recommended for:
 - water well drilling
 - geothermal
 - civil engineering

TECHNICAL CHARACTERISTICS

Top thread: 3"1/2 REG Pin
 Outside diameter: 118 mm
 Length: 1016 mm
 Bit shank: SD5
 (available with DHD350 shank)
 Pressure range: 7 to 24 bars
 Bit range: 127 to 178 mm
 Weight: 66 kg



CATEGORY

Drilling equipment

AIR CONSUMPTION

| Pressure | | Air consumption | |
|----------|-----|-----------------|-----|
| bar | psi | m3/min | cfm |
| 7 | 100 | 5.7 | 200 |
| 10 | 150 | 7.3 | 260 |
| 14 | 200 | 9.9 | 350 |
| 17 | 250 | 12.2 | 430 |
| 24 | 350 | 15.5 | 550 |

BIT FOR STENUICK05M / SD5 / COP54M

| Diameter | | Bit | | | Oversize diameter | Weight (kg) |
|----------|-------|-----|--|---|-------------------|-------------|
| mm | inch | | | | | |
| 127 | 5" | | | ● | | 15.0 |
| 140 | 5"1/2 | | | ● | | 17.0 |
| 149 | 5"7/8 | | | ● | | 18.0 |
| 152 | 6" | | | ● | | 18.0 |
| 165 | 6"1/2 | | | ● | ● | 20.0 |
| 178 | 7" | | | ● | ● | 21.0 |

SPARE PARTS LIST

| Rep. | Reference | Designation |
|------|-------------|---------------------|
| | STENUICK05M | 5" dth hammer SD5 |
| 1 | STEN05REP01 | Top adaptor |
| 2 | STEN05REP02 | O ring |
| 3 | STEN05REP03 | NR valve |
| 4 | STEN05REP04 | NR valve spring |
| 5 | STEN05REP05 | NR valve housing |
| 6 | STEN05REP06 | Spacer |
| 7 | STEN05REP07 | Plug |
| 8 | STEN05REP08 | Air distributor |
| 9 | STEN05REP09 | O ring |
| 10 | STEN05REP10 | Liner |
| 11 | STEN05REP11 | Piston |
| 12 | STEN05REP12 | Cylinder |
| 13 | STEN05REP13 | Snap ring |
| 14 | STEN05REP14 | O ring |
| 15 | STEN05REP15 | Bit retaining rings |
| 16 | STEN05REP16 | Chuck |
| 17 | | Foot valve |
| 18 | | Bit |

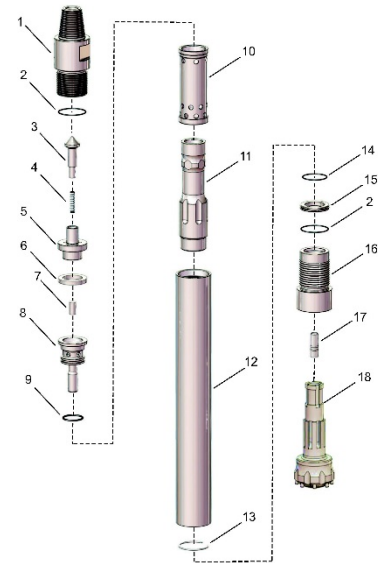

34, rue des Châtelliers
 BP 2803
 45028 Orléans Cedex 1
 Téléphone : 02 38 86 50 46
 Télécopie : 02 38 86 78 91
 Email : stenuick@stenuick.fr
 Site : www.stenuick.fr

IMPORTANT:

The technical characteristics can be modified without advance notice